

## HD51P

### SUPER HIGH RESOLUTION 600 TVL VANDAL DOME CAMERA WITH VARI-FOCAL AUTO IRIS LENS

The Performance Series rounds out Honeywell's camera portfolio with a variety of indoor, outdoor and low light cameras that lets end users pick the perfect camera for virtually any installation. Ideal for a diverse range of applications, the Performance Series includes a wide range of high performing IR bullet cameras and mini-domes that are easy to install and even easier to use.

The HD51P is a rugged dome camera incorporating a 1/3" CCD that offers 600 TV lines of crisp, clear horizontal resolution. The camera comes equipped with a built-in 3.8 – 9.5 mm Vari-focal auto Iris lens for increased optical versatility. The 3-D axis gimbal allows versatile positioning and instant centering of the video image.

The built-in breather vent effectively stops all humidity buildup to eliminate weather-related issues, loss of critical video. or possibly having to replace the camera.

The HD51P installs quickly and easily. It comes standard with a two-conductor pigtail that connects to the barrel connector so there is no need to cut wires during installation. It also features a video out port for easy focus. The HD51P is designed for use in challenging environments. It is IP66 rated for outdoor installations, but can also be installed indoors, mounted directly to a ceiling or wall.

#### Market Opportunities

The HD51P is a cost effective surveillance solution for applications that experience changing light conditions throughout the day. The HD51P offers a simple yet solid design that provides optimum performance for both indoor and outdoor applications including schools, colleges, universities, hospitals, commercial sites, industrial parks, airports, gated entrances, foyers, loading docks and driveways.

#### Features

- 1/3" Interline Transfer CCD
- Super high resolution color: 600 TV lines
- Built-in 3.8 – 9.5 mm Vari-focal Auto iris lens
- Digital Noise Reduction technology for noise free images
- Privacy zone, mirror function
- User-friendly design for easy access and adjustment of camera settings
- Vandal-proof and weather resistant housing: IP66 rating
- Built-in breather vent stops humidity buildup
- Auto White Balance
- 3-D axis gimbal
- AGC, BLC, flickerless (On/Off)
- Video out port for setup
- Two-conductor pigtail is standard for connection to barrel connector
- 12 VDC input



## SPECIFICATIONS

Operational	
Video Standard	NTSC, PAL
Scanning System	2:1 Interlace
Image Sensor	1/3" Interline Transfer CCD
Number of Pixels (H x V)	768 x 494 (NTSC) 752 x 582 (PAL)
Minimum Illumination	0.3 lux
Horizontal Resolution	600 TVL
Video Output	1.0 Vp-p, composite @ 75 Ohms
Sync System	Internal
S/N Ratio	50 dB or more (AGC Off)
Auto Gain Control	On, Off (Adjustable)
Automatic Electronic Shutter	1/60 – 1/120,000 second (NTSC) 1/50 – 1/120,000 second (PAL)
White Balance	ATW, Manual, Push
Digital Noise Reduction (DNR)	Low, Middle, High, Off
SLBC	Off, Low, Middle, High
Gamma	0.35, 0.45, 0.6, 0.75
Lens Type	3.8 – 9.5 mm DC Iris VFAI, F1.4
Angle of View	H: 70.7° - 29.2° V: 90.1° - 37.1°
Electrical	
Input Voltage	12 VDC
Input Range	12 VDC ± 10%
Power Consumption	2.2 W (max)
Mechanical	
Dimensions (W x H x D)	See Diagram
Weight	1.86 lb (0.844 kg) max
Construction	Housing: Die Cast Aluminum Dome: Polycarbonate Finish: Light gray powder coating
Connector	Main Video: BNC connector Power Input: 2.1 mm Plug

Environmental	
Temperature	Operating: 14°F to 122°F (-10°C to 50°C) Storage: -4°F to 140°F (-20°C to 60°C)
Relative Humidity	0% to 90% non-condensing
Rating	IP66
Accessories	
Power Supplies	
HPT12DC500	12 VAC/500 mA Plug-in Regulated 2.1 mm Coaxial Plug UL Listed/CSA Certified
Mounting Brackets	
HDPR-WK	Wall mount bracket
HDPR-PK	Pendant mount bracket
Regulatory	
Emissions	FCC, CE (EN55022) Class A
Immunity	CE (EN50130-4)
Safety	EU: EN 60065

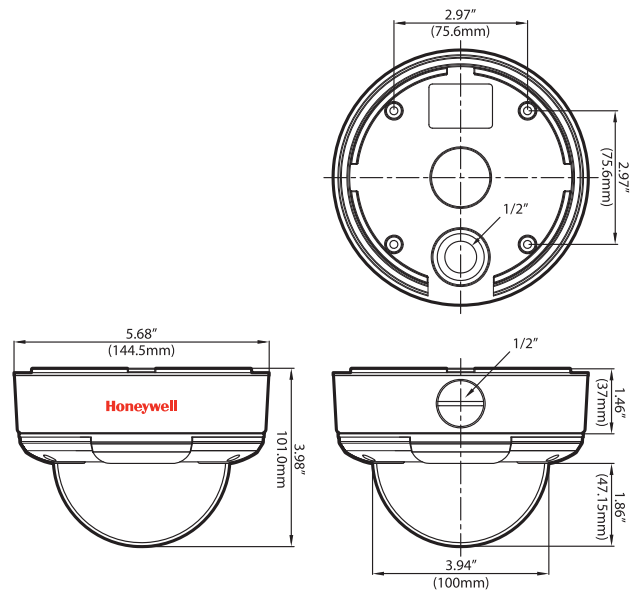

Ordering	
HD51P	1/3" CCD High Resolution Vandal Mini Dome Camera, 600 TVL, 3.8 – 9.5 mm VFAI Lens, 12 VDC, NTSC
HD51PX	1/3" CCD High Resolution Vandal Mini Dome Camera, 600 TVL, 3.8 - 9.5 mm VFAI Lens, 12 VDC, PAL

### Automation and Control Solutions

Honeywell Systems  
2700 Blankenbaker Pkwy, Suite 150  
Louisville, KY 40299  
1.800.796.2288  
www.honeywell.com

L/HD51PD/D  
September 2011  
© 2011 Honeywell International Inc.