

## HD70P

### SUPER HIGH RESOLUTION 600 TVL FIXED LENS DAY/NIGHT VANDAL DOME CAMERA WITH INFRARED ILLUMINATORS

The Performance Series rounds out Honeywell's camera portfolio with a variety of indoor, outdoor and low light cameras that lets end users pick the perfect camera for virtually any installation. Ideal for a diverse range of applications, the Performance Series includes a wide range of high performing IR bullet cameras and mini-domes that are easy to install and even easier to use.

The HD70P is a day/night camera that switches from color to black and white mode depending upon available light. The HD70P incorporates a 1/3" CCD that offers 600 TV lines of crisp, clear horizontal resolution. The HD70P utilizes smart infrared technology. Auto LED brightness adjustment provides even distribution of the IR, eliminating excessive illumination and washed out video. The camera comes equipped with 24 integrated LEDs, a built-in fixed, IR corrected lens (f=3.8 mm) and a 3-D axis gimbal that is capable of 360° of pan, 180° of tilt and 360° of horizontal rotation. In addition, the lens is separated from the LEDs by a boot mechanism which eliminates internal IR glare.

The built-in breather vent effectively stops all humidity buildup to eliminate weather-related issues, loss of critical video, or possibly having to replace the camera.

The HD70P installs quickly and easily. It comes standard with a two-conductor pigtail that connects to the barrel connector so there is no need to cut wires during installation. It also features a video out port for easy focus. The HD70P is designed for use in challenging environments. It is IP66 rated for outdoor installations, but can also be installed indoors, mounted directly to a ceiling or wall.

#### Market Opportunities

The HD70P is a cost effective surveillance solution for applications that experience changing light conditions throughout the day. The HD70P offers a simple yet solid design that provides optimum performance for both indoor and outdoor applications including lobbies, atriums, vestibules, gated entrances, foyers, loading docks and driveways.

#### Features

- 1/3" Interline Transfer CCD
- Super high resolution color: 600 TV lines
- Day/night with 24 LEDs
- Built-in fixed lens (f=3.8 mm)
- Digital Noise Reduction technology for noise free images
- Smart IR for even distribution of the IR to prevent excessive illumination
- Privacy zone, mirror function
- User-friendly design for easy access and adjustment of camera settings
- Built-in breather vent stops humidity buildup
- Vandal-proof and weather resistant housing: IP66 rating
- Total effectiveness in zero lux environments
- IR LED visible range of 50 ft. (15 m), depending on scene reflectivity
- 3-D axis gimbal
- Video out port for setup
- Two-conductor pigtail is standard for connection to barrel connector
- 12 VDC input



## SPECIFICATIONS

Operational	
Video Standard	NTSC, PAL
Scanning System	2:1 Interlace
Image Sensor	1/3" Interline Transfer CCD
Number of Pixels (H x V)	768 x 494 (NTSC) 752 x 582 (PAL)
Minimum Illumination	0.3 lux (Color/BW) / 0 lux (IR LED On)
Horizontal Resolution	600 TVL
Video Output	1.0 Vp-p, composite @ 75 Ohms
Sync System	Internal
S/N Ratio	50 dB (AGC Off)
Auto Gain Control	On, Off (Adjustable)
Automatic Electronic Shutter	1/60 – 1/120,000 second (NTSC) 1/50 – 1/120,000 second (PAL)
White Balance	ATW, Manual, Push
Digital Noise Reduction (DNR)	Low, Middle, High, Off
IR LEDs	850 nm, 24 LEDs
IR Illumination Distance (dependent on scene reflectance)	~50 ft. (15 m) Depending on scene reflectance
SBLC	Low, Middle, High, Off
Day/Night	ired, Color, B/W
Burst	On, Off
Lens Type	Built-in fixed (f=3.8 mm), IR corrected
Angle of View	H: 70° V: 51°
Electrical	
Input Voltage	12 VDC
Input Range	12 VDC ± 10%
Power Consumption	4.8 W (max), IR On
Mechanical	
Dimensions (W x H x D)	See Diagram
Weight	1.86 lb (0.844 kg) max
Construction	Housing: Die Cast Aluminum Dome: Polycarbonate Finish: Light gray powder coating
Connector	Main Video: BNC connector Power Input: 2.1 mm Plug

Environmental	
Temperature	Operating: 14°F to 122°F (-10°C to 50°C) Storage: -4°F to 140°F (-20°C to 60°C)
Relative Humidity	0% to 90% non-condensing
Rating	IP66
Accessories	
Power Supplies	
HPT12DC5300	12 VAC / 500 mA Plug-in Regulated 2.1 mm Coaxial Plug UL Listed/CSA Certified
Mounting Brackets	
HDPR-WK	Wall mount bracket
HDPR-PK	Pendant mount bracket
Regulatory	
Emissions	FCC, CE (EN55022) Class A
Immunity	CE (EN50130-4)
Safety	EU: EN 60950

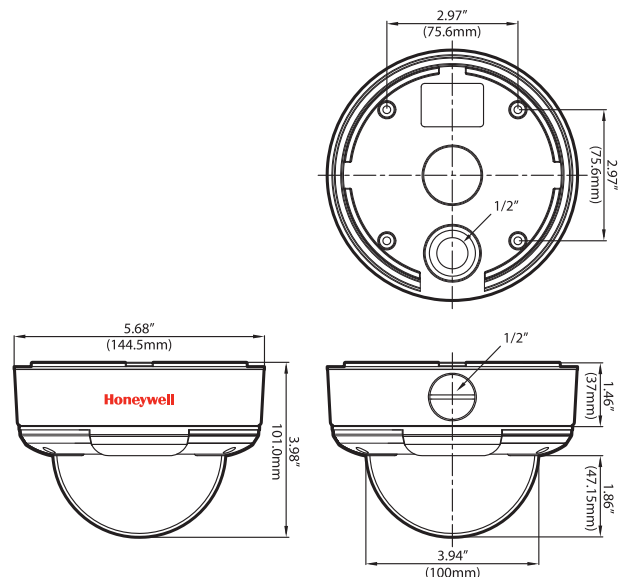

Ordering	
HD70P	1/3" CCD Integrated Day/Night Super High Resolution IR Vandal Resistant Dome Camera, 600 TVL, 24 LEDs, 3.8 Fixed Lens, 12 VDC, NTSC
HD70PX	1/3" CCD Integrated Day/Night Super High Resolution IR Vandal Resistant Dome Camera, 600 TVL, 24 LEDs, 3.8 Fixed Lens, 12 VDC, PAL

### Automation and Control Solutions

Honeywell Systems  
2700 Blankenbaker Pkwy, Suite 150  
Louisville, KY 40299  
1.800.796.2288  
www.honeywell.com

L/HD70PD/D  
October 2011  
© 2011 Honeywell International Inc.